



M I C R O T U N E ®

RF SILICON AND SUBSYSTEMS SOLUTIONS
FOR BROADBAND COMMUNICATIONS AND AUTOMOTIVE ELECTRONICS

MT2121 SINGLE-CHIP BROADBAND TUNER

PRODUCT BRIEF

The MT2121 has been optimized for high-performance analog and digital cable set-top boxes, supporting the 48 MHz to 1 GHz range of the cable spectrum.



*MT2121 Single-Chip
Broadband Tuner*

The MicroTuner™ MT2121 is a fully integrated single-chip tuner, with functional blocks specifically designed to ease implementation of an OpenCable™ - compliant set-top box (STB). The MT2121 contains integrated filter components and controls that allow for a simple, alignment-free pre-select filter. This provides excellent end-to-end linearity performance for severely sloped input conditions. The tuner also has an on-chip amplifier for Forward Data Channel (FDC) applications, reducing bill of materials (BOM) and improving performance-versus-solutions based on a directional coupler.

APPLICATIONS

All cable-based applications

- Advanced analog/digital set-top boxes including OpenCable
- Residential gateways
- Home entertainment servers

FEATURES

- Dual-conversion architecture for consistent performance with no manual alignments
- Proven performance in dual-function analog and digital set-top box designs
- Eliminates the need for the 28V to 33V supplies typically required by traditional cable tuners
- 3.3V and 5V serial bus compatible
- Minimal external components; simple interface to external filters
- Software shutdown mode
- Small 8mm x 8mm 56-lead QFN Quad Flat package available in lead-free
- Can be used in conjunction with Microtune's upstream amplifiers to create a complete RF front end for bi-directional set-top box applications

M I C R O T U N E

MT2121 SINGLE-CHIP BROADBAND TUNER

PRODUCT BRIEF

RECOMMENDED OPERATING CONDITIONS

PARAMETER	MIN	TYP	MAX	UNIT
Input frequency range	48		1000	MHz
First intermediate center frequency		1220		MHz
Second intermediate center frequency (programmable)	30		57	MHz
Supply voltage, 5V	4.75		5.25	V
Supply voltage, 3.3V	3.15		3.45	V
Supply voltage ripple			15	mV
DNC differential load impedance		800		Ω
Serial control clock			400	kHz

TUNER ELECTRICAL CHARACTERISTICS

PARAMETER	CONDITION	TYP
Power supply	5.0V	270 mA
	3.3V	80 mA
Noise figure 48-1000 MHz	At max RF AGC. Measured at DNC output.	10.8 dB
Input return loss	Referred to 75 Ω	9 dB
RF gain range	0V to 3.3V control voltage	30 dB
IF gain range	0.7V to 3.3V control voltage	30 dB
Image rejection	Undesired 90 MHz higher in frequency.	70 dB
Phase noise	10kHz	-85 dBc/Hz
	100kHz	-105 dBc/Hz
Serial control clock frequency		400 kHz
Noise figure, max RF gain and IF gain, at VGA output 48-1000 MHz	RFAGC at 3.3V. Measured at VGA output with FDC connected.	11.1 dB
FDC Gain		1.0 dB
FDC Noise figure		12 dB
FDC Frequency Range		70-130 MHz

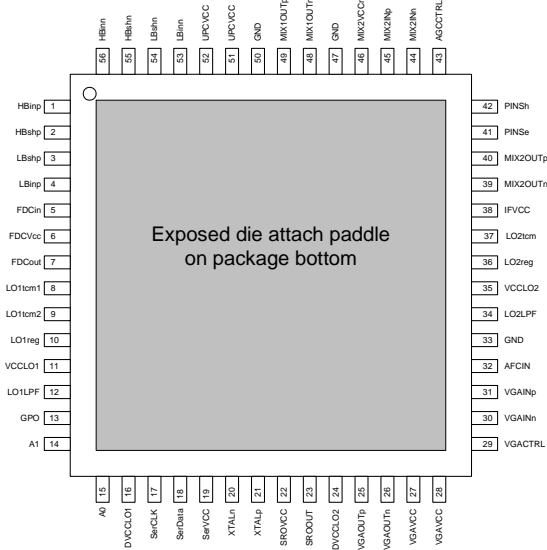

MT2121 Pin Diagram

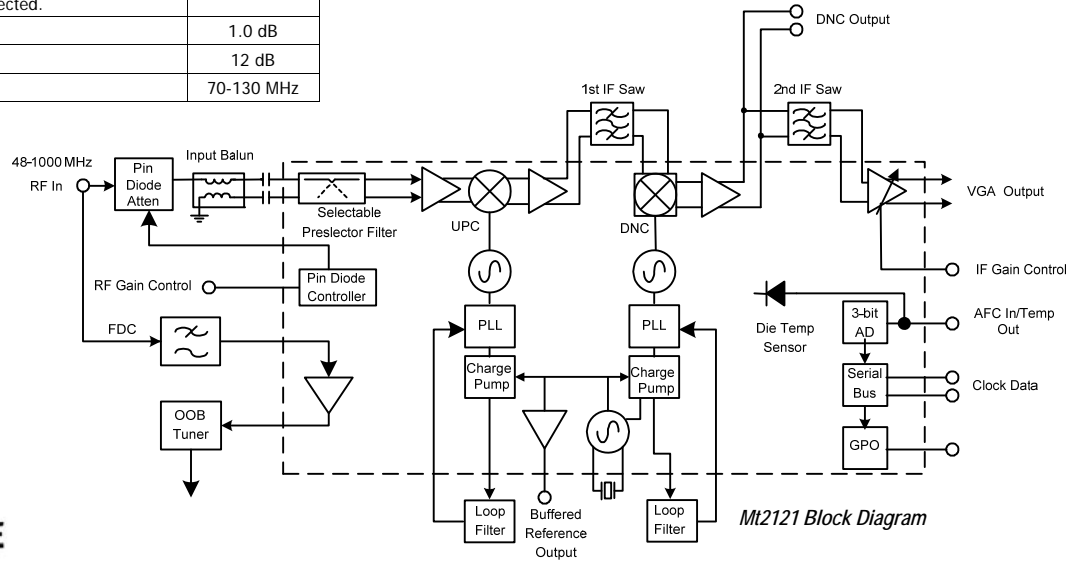

MT2121 Block Diagram



Microtune, Inc., 2201 10th Street, Plano, TX 75074, USA

Tel: +1-972-673-1600, Fax: +1-972-673-1602, E-mail: sales@microtune.com, Web site: www.microtune.com

For a detailed list of office locations, sales offices, and sales representatives, visit our web site at www.microtune.com

Microtune believes that the information in this document is accurate and reliable, as of the date of this document. Microtune assumes no responsibility for any consequences arising from the use of this information, nor from any infringement of patents or the rights of third parties which may result from its use. No license is granted by implication or otherwise under any patent or other rights of Microtune. The information in this publication replaces and supersedes all information previously supplied, and is subject to change without notice. The customer is responsible for assuring that proper design and operating safeguards are observed to minimize inherent and procedural hazards. Microtune assumes no responsibility for applications assistance or customer product design.

The devices described in this document are not authorized for use in medical, life-support equipment, or any other application involving a potential risk of severe property or environmental damage, personal injury, or death without prior express written approval of Microtune. Any such use is understood to be entirely at the user's risk.

Microtune is a registered trademark of Microtune, Inc. MicroTuner, MicroStreamer, VideoCaster, DataCaster, ClearTune, and the Microtune logo are trademarks of Microtune, Inc. All other trademarks belong to their respective companies.

Microtune's products are protected by one or more of the following U.S. patents: 5,625,325; 5,648,744; 5,717,730; 5,737,035C1; 5,739,730; 5,805,988; 5,847,612; 6,100,761; 6,104,242; 6,163,684; 6,169,569; 6,172,378; 6,177,964; 6,211,745; 6,218,899; 6,268,778; 6,310,387; 6,323,736; 6,355,537; 6,429,502; 6,462,327; 6,535,068; 6,580,313; 6,608,522; 6,631,257; 6,714,776; 6,725,463; 6,744,308; 6,771,124; 6,784,945; 6,804,099; 6,888,406; 6,891,435; 6,906,594; 6,909,886; 6,919,774; 6,920,182; 6,922,556; 6,963,478; 6,973,288; 6,993,310; 7,035,614; 7,039,062; 7,078,960; 7,079,195; 7,119,834; 7,164,899; 7,171,176; 7,184,724; 7,190,942; 7,190,943; 7,242,918; 7,274,410; 7,304,689; 7,304,533; 7,304,393; 7,313,201; 7,319,849; 7,333,791; 7,359,686; 7,369,827; 7,376,407; 7,388,437; 7,436,262; 7,444,126; 7,446,692; D469,742 and additional patents pending or filed.

Microtune's products are protected by one or more of the following International patents:

United Kingdom: 1225700; 1532732; Germany: 602298894.6; 60313621.4; Netherlands: 1225700; 1532732; France: 1225700; 1532732; and additional patents pending or filed.

Entire contents Copyright © 1996 - 2010 Microtune, Inc.

011609