



M I C R O T U N E ®

RF SILICON AND SUBSYSTEMS SOLUTIONS
FOR BROADBAND COMMUNICATIONS AND AUTOMOTIVE ELECTRONICS

MT2062 SINGLE-CHIP BROADBAND TUNER

PRODUCT BRIEF

The MT2062 is a low-power 3.3 V single-chip broadband tuner with integrated loop-through for all-digital set-top boxes.



MT2062 Single-Chip Broadband Tuner

The MicroTuner™ MT2062 is an advanced, low-power single-chip broadband tuner, with loop-through, optimized for Digital Video Broadcast via Cable (DVB-C) set-top boxes.

The MT2062 is capable of receiving frequencies in the 48 MHz to 862 MHz range and of converting a selected channel to a standard intermediate frequency (IF) between 30 MHz and 60 MHz.

The MT2062 dual-conversion architecture, without any need for tracking filters, yields the desirable characteristics of traditional cable television tuners. This is achieved by careful control of the input impedance across the entire input band, low in-band emissions, and outstanding image rejection.

To keep the total Bill of Materials (BOM) cost of a digital set-top box low, the MT2062 has an integrated on-chip loop-through function. In addition, the MT2062 provides excellent in-band flatness as well as very repeatable gain characteristics across the complete reception band.

APPLICATIONS

- DVB-C Set-top Boxes with loop-through

FEATURES

- 48 MHz to 862 MHz input frequency range
- 3.3 V power supply
- Works seamlessly with all digital demodulators
- Low-power 1 Watt dual-conversion architecture
- Integrated first IF filter
- Integrated loop-through function
- Single-ended RF input reduces BOM by eliminating input balun
- Minimal external components
- No manually tunable parts required
- Integrated IF variable gain amplifier for direct connection to digital demodulators
- Fully compatible with all DVB-C standards
- Capable of driving multiple SAW filters

RECOMMENDED OPERATING CONDITIONS

PARAMETER	MIN	TYP	MAX	UNIT
Input frequency range	48		862	MHz
Second intermediate center frequency (programmable)	30		60	MHz
Supply voltage	3.15	3.3	3.45	V
Supply voltage ripple			25	mVp-p
Operating junction temperature			100	°C
VGA output load impedance	200			Ω
Serial control clock			400	kHz

ABSOLUTE MAXIMUM RATINGS

PARAMETER	MIN	MAX	UNIT
Supply voltage		3.6	V
Storage temperature range	-40	+150	°C
Lead temperature (soldering 4 seconds)		+245	°C
Input voltage	-0.3	VCC +0.3	V

TUNER ELECTRICAL CHARACTERISTICS

PARAMETER	MIN	TYP	MAX	UNIT
Power Supply				
Active current		280		mA
RF Signal Path				
Input frequency range	48		862	MHz
Return loss		7		dB
Noise figure at max gain		7		dB
Terminal voltage gain		48		dB
RF AGC range		35		dB
Image rejection		70		dBc
LO phase noise (10 kHz)		-87		dBc/Hz
LO phase noise (100 kHz)		-105		dBc/Hz
LO step size	50			kHz
IF VGA				
Frequency range	30		60	MHz
Output voltage			2.0	Vp-p
Terminal voltage gain		52		dB
Loop-through gain		2		dB

PRELIMINARY

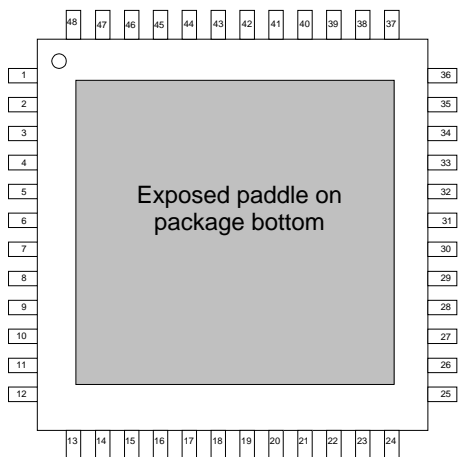

MT2062 Pin Diagram

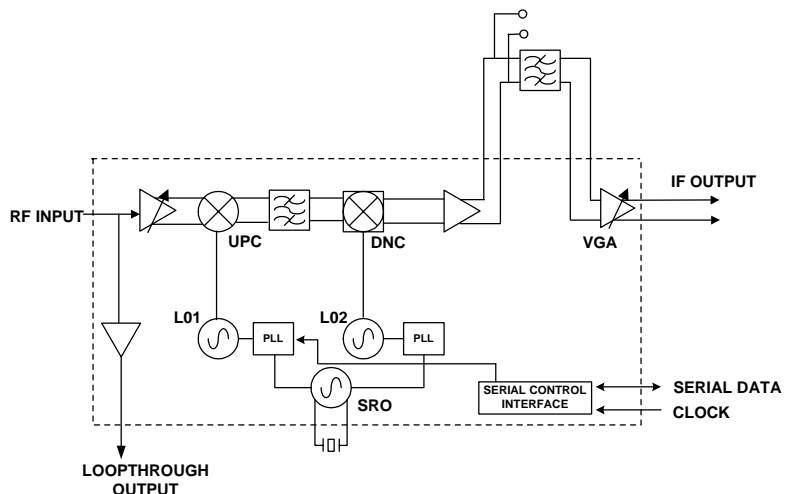

MT2062 Block Diagram



Microtune, Inc., 2201 10th Street, Plano, TX 75074, USA

Tel: +1-972-673-1600, Fax: +1-972-673-1602, E-mail: sales@microtune.com, Web site: www.microtune.com

For a detailed list of office locations, sales offices, and sales representatives, visit our web site at www.microtune.com

Microtune believes that the information in this document is accurate and reliable, as of the date of this document. Microtune assumes no responsibility for any consequences arising from the use of this information, nor from any infringement of patents or the rights of third parties which may result from its use. No license is granted by implication or otherwise under any patent or other rights of Microtune. The information in this publication replaces and supersedes all information previously supplied, and is subject to change without notice. The customer is responsible for assuring that proper design and operating safeguards are observed to minimize inherent and procedural hazards. Microtune assumes no responsibility for applications assistance or customer product design.

The devices described in this document are not authorized for use in medical, life-support equipment, or any other application involving a potential risk of severe property or environmental damage, personal injury, or death without prior express written approval of Microtune. Any such use is understood to be entirely at the user's risk.

Microtune is a registered trademark of Microtune, Inc. MicroTuner, MicroStreamer, VideoCaster, DataCaster, ClearTune, and the Microtune logo are trademarks of Microtune, Inc. All other trademarks belong to their respective companies.

Microtune's products are protected by one or more of the following U.S. patents: 5,625,325; 5,648,744; 5,717,730; 5,737,035; 5,739,730; 5,805,988; 5,847,612; 6,100,761; 6,104,242; 6,163,684; 6,169,569; 6,172,378; 6,177,964; 6,211,745; 6,218,899; 6,268,778; 6,310,387; 6,323,736; 6,355,537; 6,429,502; 6,462,327; 6,535,068; 6,580,313; 6,608,522; 6,631,257; 6,714,776; 6,725,463; 6,744,308; 6,771,124; 6,784,945; 6,804,099; 6,888,406; 6,891,435; 6,906,594; 6,909,886; 6,919,774; 6,920,182; 6,922,556; 6,963,478; 6,973,288; 6,993,310; 7,035,614; 7,078,960; 7,079,195; 7,164,899; 7,171,176; 7,184,724; 7,190,942; 7,190,943; D469,742 and additional patents pending or filed.

Entire contents Copyright © 1996 - 2008 Microtune, Inc.

062007