



M I C R O T U N E ®

MT2022 SINGLE-CHIP MoCA®-COMPATIBLE BROADBAND TUNER PRODUCT BRIEF

The MT2022 is a single-chip broadband tuner designed for superior performance with MoCA systems.



MT2022 Single-Chip Broadband Tuner

RF SILICON AND SUBSYSTEMS SOLUTIONS
FOR BROADBAND COMMUNICATIONS AND AUTOMOTIVE ELECTRONICS

The MicroTuner MT2022 is an advanced single-chip broadband tuner that has been optimized for high-performance analog and digital cable set-top boxes that require low composite distortion and noise under fully loaded (174 channels) cable environments. It is capable of receiving frequencies in the 48 MHz to 1.1 GHz range and of converting a selected channel to an intermediate frequency (IF).

The MT2022's dual-conversion architecture, with no requirement for tracking filters, yields the desirable characteristics of traditional cable television tuners: controlled input impedance across the input band, low in-band emissions, and good selectivity.

The device is highly integrated, with on-chip components including a low noise amplifier (LNA), a first mixer that up-converts the input spectrum to a first IF of 1690 MHz, an image-reject mixer that downconverts the filtered first IF spectrum to a standard second IF, a buffer amplifier for the IF output, an IF variable gain amplifier, and a serial interface to program the device as well as read back its status.

On-chip phase-locked loops (PLLs) and voltage-controlled oscillators (VCOs) create a fully integrated frequency synthesis system, which runs off a single external crystal. The use of high First Intermediate Frequency (FIF) allows unhindered transmission of Multimedia over Coax Alliance (MoCA®) band signals. The image-reject mixer provides excellent image rejection and eases the requirements of the first IF filter.

APPLICATIONS

- DSG in cable STBs
- All-digital cable STBs

FEATURES

- The MT2022 features many advantages including:
- On-chip amplifier for Forward Data Channel (FDC), which reduces bill of materials (BOM) cost while improving performance vs. solutions using a directional coupler.
- 1.1 GHz bandwidth
- Ease of multi-tuner front-end implementations
- Proven performance in dual-function digital STB designs
- Eliminates the need for the 28V to 33V supplies typically required by traditional tuners
- 3.3V and 5V serial bus compatible
- Minimal external components
- No manually tuned parts required
- Simple interface to external filters
- Software shutdown mode
- Intermediate frequency (IF) output fully compatible with demodulators for DSG, DAVIC, DVB-C, DOCSIS™, EuroDOCSIS™, and other standards
- Can be used in conjunction with MicroTune's upstream amplifiers to create a complete RF front end for bi-directional STB applications

M I C R O T U N E

MT2022 SINGLE-CHIP BROADBAND TUNER

PRODUCT BRIEF

RECOMMENDED OPERATING CONDITIONS

PARAMETER	MIN	TYP	MAX	UNIT
Input frequency range	48		1100	MHz
Second intermediate center frequency (programmable)	30		57	MHz
Supply voltage, +3.3V	3.15	3.3	3.45	V
Supply voltage, +5V	4.75	5.0	5.25	V
Supply voltage ripple			15	mVp-p
Operating junction temperature			100	°C
VGA differential output load impedance	300			Ω
Serial control clock			400	kHz
DNC differential load impedance	800			Ω

ABSOLUTE MAXIMUM RATINGS

PARAMETER	MIN	MAX	UNIT
Supply voltage, +3.3V		3.6	V
Supply voltage, +5V		6	V
Storage temperature range	-50	+150	°C
Lead solder temperature (4 seconds)		+245	°C
Lead Free solder temperature (5 seconds)		+260	°C
Junction temperature		+125	°C

TUNER ELECTRICAL CHARACTERISTICS

PARAMETER	MIN	TYP	MAX	UNIT
Power Supply				
Active current, 3.3V		73		mA
Active current, 5V		259		mA
RF Signal Path (See figure 2)				
Input frequency range	48		1100	MHz
Noise figure (DNC Out) 50-855 MHz		10.5		dB
855-1100 MHz		11.5		dB
RF AGC range		30		dB
Image rejection		70		dB
LO phase noise (10 kHz)		-82		dBc/Hz
LO phase noise (100 kHz) 50-855 MHz		-104		dBc/Hz
LO phase noise (100 kHz) 855-1100 MHz		-102		dBc/Hz
LO1 step size		250		kHz
LO2 step size		2		kHz
IF VGA				
Frequency range	30		57	MHz
Output voltage swing		1.0		Vp-p
Voltage gain, VGACTRL = 0.7 to 3.3V	<16.5		>47.5	dB
IF AGC range		33		dB
FCDA				
Frequency range	70		130	MHz
Gain	-2.5	1.0		dB
Noise Figure		12		dB

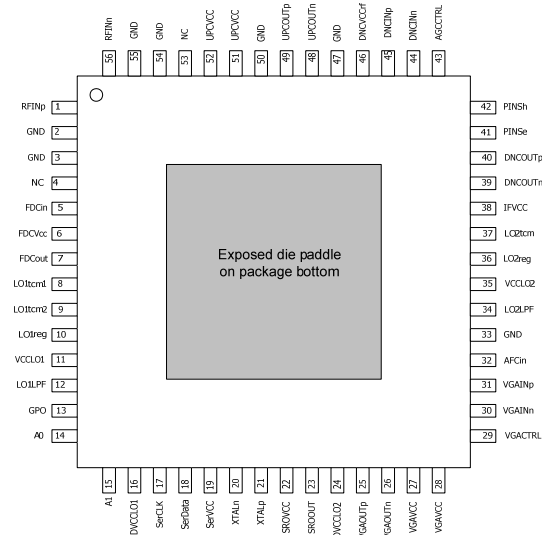

Figure 1 MT2022 Pin Diagram

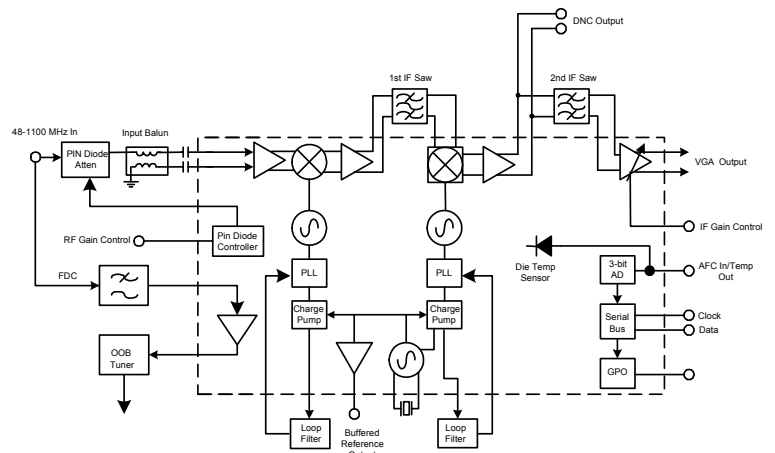

Figure 2 MT2022 Block Diagram



MicroTune, Inc., 2201 10th Street, Plano, TX 75074, USA

Tel: +1-972-673-1600, Fax: +1-972-673-1602, E-mail: sales@microtune.com, Web site: www.microtune.com

For a detailed list of office locations, sales offices, and sales representatives, visit our web site at www.microtune.com

MicroTune believes that the information in this document is accurate and reliable, as of the date of this document. MicroTune assumes no responsibility for any consequences arising from the use of this information, nor from any infringement of patents or the rights of third parties which may result from its use. No license is granted by implication or otherwise under any patent or other rights of MicroTune. The information in this publication replaces and supersedes all information previously supplied, and is subject to change without notice. The customer is responsible for assuring that proper design and operating safeguards are observed to minimize inherent and procedural hazards. MicroTune assumes no responsibility for applications assistance or customer product design.

The devices described in this document are not authorized for use in medical, life-support equipment, or any other application involving a potential risk of severe property or environmental damage, personal injury, or death without prior express written approval of MicroTune. Any such use is understood to be entirely at the user's risk.

MicroTune is a registered trademark of MicroTune, Inc. MicroTuner, MicroStreamer, VideoCaster, DataCaster, ClearTune, and the MicroTune logo are trademarks of MicroTune, Inc. All other trademarks belong to their respective companies.

MicroTune's products are protected by one or more of the following U.S. patents: 5,625,325; 5,648,744; 5,717,730; 5,737,035C1; 5,739,730; 5,805,988; 5,847,612; 6,100,761; 6,104,242; 6,163,684; 6,169,569; 6,172,378; 6,177,964; 6,211,745; 6,218,899; 6,268,778; 6,310,387; 6,323,736; 6,355,537; 6,429,502; 6,462,327; 6,535,068; 6,580,313; 6,608,522; 6,631,257; 6,714,776; 6,725,463; 6,744,308; 6,771,124; 6,784,945; 6,804,099; 6,888,406; 6,891,435; 6,906,594; 6,909,886; 6,919,774; 6,920,182; 6,922,556; 6,963,478; 6,973,288; 6,993,310; 7,035,614; 7,039,062; 7,078,960; 7,079,195; 7,119,834; 7,164,899; 7,171,176; 7,184,724; 7,190,942; 7,190,942; 7,242,918; 7,274,410; 7,304,689; 7,304,533; 7,304,393; 7,313,201; 7,319,849; 7,333,791; 7,359,686; 7,369,827; 7,376,407; 7,388,437; 7,436,262; 7,444,126; 7,446,692; D469,742 and additional patents pending or filed.