



M I C R O T U N E ®

RF SILICON AND SUBSYSTEMS SOLUTIONS
FOR BROADBAND COMMUNICATIONS AND AUTOMOTIVE ELECTRONICS

MT2122 SINGLE-CHIP BROADBAND TUNER

PRODUCT BRIEF

The MT2122 is a fully integrated broadband tuner for analog and digital OpenCable set-top boxes, home gateways, cable modems and HDTV applications.



MT2122 Single-Chip Broadband Tuner

The MicroTuner™ MT2122 is a fully integrated single-chip tuner, with functional blocks specifically designed to ease implementation of high-performance analog and digital OpenCable™ set-top boxes. It supports advanced analog/digital set-top boxes (STB) including OpenCable™, home gateways, cable modems and HDTV applications.

The MT2122 has been developed to give manufacturers design flexibility at low cost without compromising high performance.

The MT2122 receives signal from 48 – 1100 MHz. It features integrated filter components and controls that allow for a simple, alignment-free pre-select filter. This provides excellent end-to-end linearity performance in severely sloped input conditions. MT2122 greatly reduces complexity for the Multimedia over Coax Alliance (MoCA™) applications.

Its dual-conversion architecture ensures consistent OpenCable - compliant performance with no manual alignment. The on-chip buffer amplifier for Forward Data Channel (FDC) reduces bill of materials (BOM) cost while improving performance compared to solutions using a directional coupler.

The MT2122 includes a PIN diode attenuator linearizer circuit that can drive a PI-network pin diode attenuator in the signal path. The MT2122 also supports multi-tuner front-end implementations and is programmable through a serial bus interface.

APPLICATIONS

- Advanced analog and digital set-top boxes (STB) including OpenCable.
- Home gateways
- Cable modems
- HDTV

FEATURES

- Output fully compatible with demodulators for MoCA, NTSC, PAL, SECAM, DAVIC, DVB-C, DOCSIS®, Euro-DOCSIS™, OpenCable and other standards
- On-chip amplifier for Forward Data Channel (FDC)
- Ease of multi-tuner front-end implementations
- Dual-conversion architecture for consistent OpenCable compliant performance
- Serial control interface
- One general purpose output controllable via serial control interface
- On-chip frequency synthesis system integrating PLL, VCOs and varactors.
- 1.1 GHz bandwidth
- No need for the 28 V to 33 V supplies typically required by traditional cable tuners
- Automatic frequency control (AFC) voltage detector for frequency fine-tuning
- Integrated temperature sensor for thermally sensitive systems
- 3.3 V and 5 V serial bus compatible
- No tunable parts required
- Simple interface to external filters
- Software shutdown mode
- Small 8 mm x 8 mm 56-pin QFN package

M I C R O T U N E

MT2122 SINGLE-CHIP BROADBAND TUNER
PRODUCT BRIEF

RECOMMENDED OPERATING CONDITIONS

PARAMETER	MIN	Typ	MAX	UNIT
Input frequency range	48		1100	MHz
First intermediate center frequency		1690		MHz
Second intermediate frequency (programmable)	30		60	MHz
Supply voltage 5 V	4.75	5.0	5.25	V
Supply voltage 3.3 V	3.15	3.3	3.45	V
Supply voltage ripple			15	mV
Operating junction temperature			125	°C
VGA differential output load impedance	300			Ω
Serial control clock			400	kHz
MIX2 differential load impedance	800			Ω

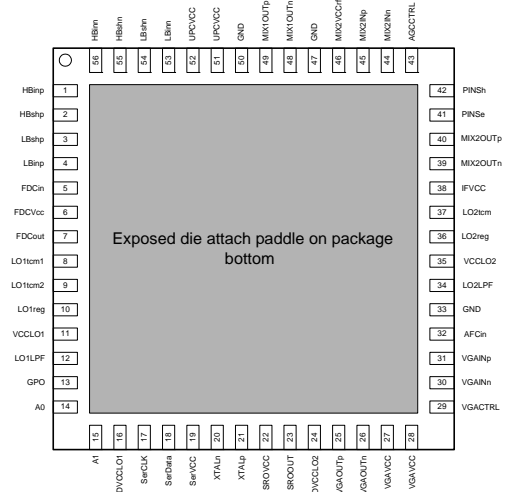

ABSOLUTE RATINGS

PARAMETER	MIN	MAX	UNIT
Supply voltage, +5 V		6	V
Supply voltage, +3.3 V		3.6	V
Junction temperature		125	°C
Storage temperature	-50	150	°C
Lead-free solder temperature for 5 seconds		260	°C
Relative humidity		95	%
Input voltage	-0.3	VCC +0.3	V

MT2122 Pin Diagram

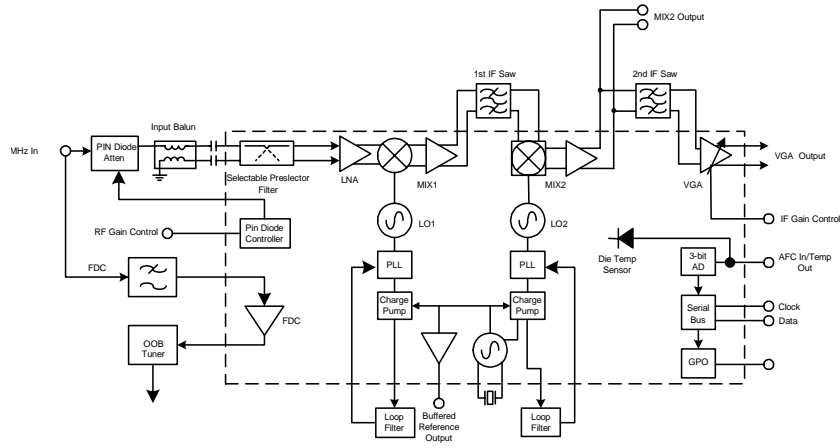

MT2122 Block Diagram



Microtune, Inc., 2201 Tenth Street, Plano, TX 75074, USA

Tel: +1-972-673-1600, Fax: +1-972-673-1602, E-mail: sales@microtune.com, Web site: www.microtune.com

For a detailed list of design centers, sales offices, and sales representatives, visit our Web site at www.microtune.com

The information in this document is believed to be accurate and reliable. Microtune assumes no responsibility for any consequences arising from the use of this information, nor from any infringement of patents or the rights of third parties which may result from its use. No license is granted by implication or otherwise under any patent or other rights of Microtune. The information in this publication replaces and supersedes all information previously supplied, and is subject to change without notice. The customer is responsible for assuring that proper design and operating safeguards are observed to minimize inherent and procedural hazards. Microtune assumes no responsibility for applications assistance or customer product design.

The devices described in this document are not authorized for use in medical, life-support equipment, or any other application involving a potential risk of severe property or environmental damage, personal injury, or death without prior express written approval of Microtune. Any such use is understood to be entirely at the user's risk.

Microtune is a registered trademark of Microtune, Inc. MicroTuner, MicroStreamer, VideoCaster, DataCaster, and the Microtune logo are trademarks of Microtune, Inc. All other trademarks belong to their respective companies.

Microtune's products are protected by one or more of the following U.S. patents: 5,625,325; 5,648,744; 5,717,730; 5,737,035; 5,739,730; 5,805,988; 5,847,612; 6,100,761; 6,104,242; 6,163,684; 6,169,569; 6,172,378; 6,177,964; 6,211,745; 6,218,899; 6,268,778; 6,310,387; 6,323,736; 6,355,537; 6,429,502; 6,462,327; 6,535,068; 6,580,313; 6,608,522; 6,631,257; 6,714,776; 6,725,463; 6,744,308; 6,771,124; 6,784,945; 6,804,099; 6,888,406; 6,891,435; 6,906,594; 6,909,886; 6,920,182; 6,922,556; 6,963,478; 6,973,288; 6,993,310; 7,035,614; D469,742 and additional patents pending or filed.